



Full-View Aluminum Doors

- Ideal for maximizing benefits of high visibility and natural light
- Lightweight but extremely rugged construction
- Virtually maintenance-free, even in harsh environments
- Wide range of finish colors and glazing options
- Substantial solar heat gain

Quality Door Solutions
Since 1947

Full-View Aluminum Doors

Built to withstand rigorous use in a busy service center, yet offering a clean, contemporary look for many types of architectural applications, General Doors' Full-View Aluminum Door is an attractive choice when natural light and open visibility are important. Typical installations are as diverse as auto service centers, firehouses, club stores, and upscale retail and restaurant locations.

Appearance

A classic design with unlimited options in configurations, finishes, and glazing materials that combine to create a door that achieves a fresh and modern look.

Strength

Heavy gauge parts, 4-sided extrusions, built-in reinforcing fin, and unique wrap around steel end cap make for a very heavy-duty door.

Durability

Aluminum doors are naturally resistant to the deterioration caused by the elements and are an excellent choice for many environments not suited to wood or steel doors.

Options

- Frames
 - Standard finishes are clear anodized, factory pre-painted white, or bronze anodized
 - Custom colors are powder coated using a selection of 188 stock RAL colors (RALcolor.com)
- Glazing
 - 1/8", 1/4", or 1/2" thicknesses
 - Glass or acrylic, clear or tinted
 - Single wall or insulated
- Solid aluminum panel sections — usually for bottom, but can be used for any section
- Solid insulated 1-3/4" thick urethane sections with stucco embossed steel skins usually for bottom, but can be used for any section
- Exhaust ports
- Top seal, jamb seal
- Extra long life torsion springs (25M, 50M, 100M)
- Pass door — 3-1/2 sections high



Aluminum panel bottom section



Insulated steel bottom section



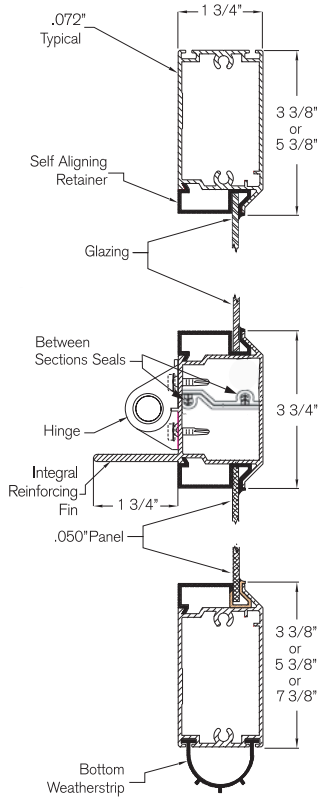

Standard Colors

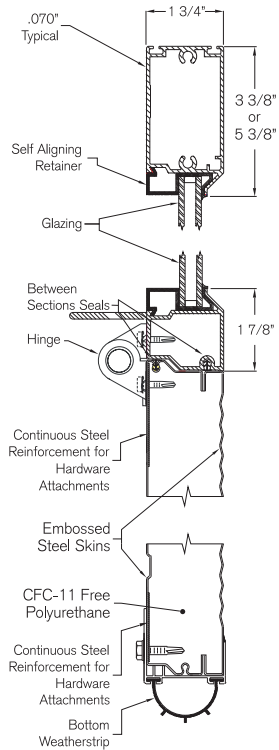
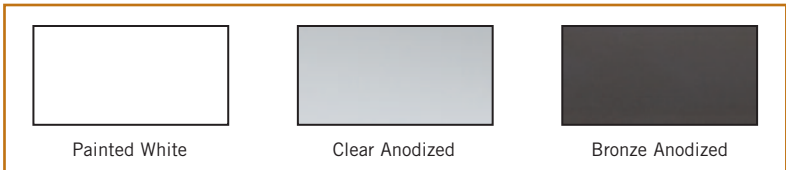

Specifications

Manufacturer: General Doors Corporation, which is located at 1 Monroe St., Bristol, PA 19007
Tel: 215-788-9277; Fax: 215-788-9450
E-mail: sales@general-doors.com
Web: www.general-doors.com

Sections are 1-3/4" thick extruded 6053-T5 aluminum with integral reinforcing fin at each intermediate rail; all stiles and rails are 4-sided extrusions, secured with 1/4" diameter bolts.

Available standard as clear anodized, bronze anodized, or factory pre-painted white. Optional custom powder coated or anodized frame finishes are available in a wide variety of choices.

Standard Door: end stiles, top and bottom rail have 3" face; center stiles have 1-1/4" face.

Heavy Frame Door: end stiles and bottom rail have 5" or 7" face, depending on size. Top rail has 5" face and center stiles have 3" face.

Shiplap meeting rails with continuous, replaceable dual seals between sections.

Bottom section supplied with flexible U-shaped PVC astragal.

All glazing and solid panels are completely wrapped in a flexible vinyl channel and held in place with a rigid snap-lock retainer.

Meets or exceeds standards of ANSI/DASMA 102-2011, Specifications for Sectional Doors.



Green Building Benefits

- Recycled content and recyclable material
- Visible light transmittance
- Substantial solar heat gain
- Cycle life (long-lasting product)
- Regional manufacturing (less transportation)
- No on-site finishing required (no VOCs introduced)

Glazing options include (but are not limited to):

- 1/8" clear DSB (double strength) or tempered glass
- 1/2" clear insulated glass or tempered insulated glass units
- 1/8" clear acrylic
- 1/4" clear polycarbonate (Lexan)
- 1/4" twin-wall (ribbed) polycarbonate

Solid panel options:

Smooth — .050" thick aluminum panels, clear or bronze anodized or pre-painted white.

Embossed — .017" aluminum skins laminated to a core of either polystyrene (for insulation) or plywood (for strength).

Solid section option:

1-3/4" thick section of Steel/Polyurethane/Steel sandwich type construction. Exterior skin is stucco embossed .019" hot-dipped galvanized steel in 6-rib or multi-rib design, pre-painted in white, brown, or silver (Model WB175 sections).

SECTION GUIDE

Door Height	No. of Sections
7'1" to 8'1"	4
8'2" to 10'1"	5
10'2" to 12'1"	6
12'2" to 14'1"	7
14'2" to 16'1"	8
16'2" to 18'1"	9

PANEL GUIDE

Door Width	No. of Panels
Up to 9'2"	2
9'3" to 12'2"	3
12'3" to 16'2"	4
16'3" to 20'2"	5
20'3" to 24'2"	6

Model	Standard	Heavy Frame (HF)		
Width up to	14'2"*	14'2"	18'2"	24'2"
Bottom rail	3-3/8"	3-3/8"	5-3/8"	7-3/8"
Top rail	3-3/8"	3-3/8"	5-3/8"	5-3/8"
End stiles	3-3/8"	5-3/8"	7-3/8"	7-3/8"
Center stiles	2"	3-1/2"	3-1/2"	3-1/2"
Meeting rails	3-3/4"	3-3/4"	3-3/4"	3-3/4" combined

*Please contact manufacturer if door is to have more than 144 sq ft of insulated glass.

Warranty

1-year warranty on materials and workmanship. See dealer for complete warranty details.



1 Monroe Street
PO Box 205 • Bristol, PA 19007-0205
215.788.9277 • Fax: 215.788.9450
general-doors.com
sales@general-doors.com

GENERAL DOORS
Corporation

Your Authorized General Doors Distributor: